

VEHICLES HEATERS

B1L (gasoline)

D1L (diesel fuel)

Air heaters independent of engine
for universal installation

J. EBERSPÄCHER
EBERSPÄCHERSTRASSE 24
D-7300 ESSLINGEN
TEL. (07 11) 3109-0
TELEX 7 256 426
TELEFAX (07 11) 3109-6 26

B 1 L	Cat. no.
Basic heater with standard equipment	12 V 20 1590 05 00 00
Universal installation kit	20 1575 80 00 00

D 1 L	Cat. no.
Basic heater with standard equipment	12 V 25 1384 05 00 00 24 V 25 1385 05 00 00
Universal installation kit	12 V 25 1637 05 00 00 ⁴⁾ 24 V 25 1638-05 00 00 ⁴⁾ 20 1575 80 00 00

Control elements (to be ordered separately, see page 2).
See Additional Equipment Catalog for other accessories.

Control elements (to be ordered separately, see page 2).
See Additional Equipment Catalog for other accessories.

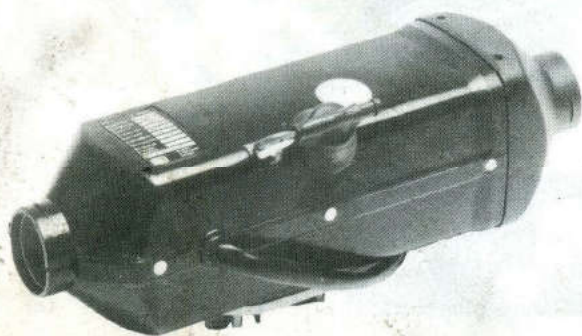

Specifications

Heating medium	Air
Hot air throughput ¹⁾ (without counterpressure)	100 kg/h ± 10 %
Heating capacity ¹⁾	1800 W ± 10 %
Fuel (see also page 10)	B 1 L: Gasoline, (commercial grade) D 1 L: Diesel fuel, (commercial grade)
Fuel consumption ¹⁾	B 1 L: 0.24 l/h ± 5 % D 1 L: 0.21 l/h ± 5 %
Rated voltage	12 V or 24 V
Operating range:	
Lower voltage limit ²⁾	10 V or 20 V
Upper voltage limit ³⁾	14 V or 28 V
Electrical power consumption ¹⁾	B 1 L at start 200 W ± 10 % operating 40 W ± 10 %

D 1 L	
at start	12 V = 260 W ± 10 % 24 V = 500 W ± 10 %
operating	40 Watt ± 10 %
Ventilation	Possible with suitable circuits
Degree of radio inter- ference suppression	Remote; additional interference suppression measures possible
Weight	approx. 3 kg

- 1) at rate voltage
- 2) an undervoltage safety device built into the control unit switches off the heaters when at approx. 10.5 and 21 V respectively.
- 3) an overvoltage safety device built into the control unit switches off the heaters when at approx. 15 V and 30 V respectively.
- 4) with glow plug current regulator

Contents	Page
Scope of delivery/Cat. No.	2, 3
Official regulations	4
Installation instructions	4
Typical installations/installation location	4, 5
Installing the heater	5
Principal dimensions	5
Permissible installation positions/Fastening methods	6
Running the heating air/determination of rating	7
Running the combustion air	8
Running the exhaust	8
Fuel supply	9, 10
Fuel at low temperatures	10
Electrics/Wiring diagrams	11 – 16
Description of operation	17, 18
Malfunctions	18

Scope of delivery:

Item	Qty.	Design/Cat. No
B 1 L		
1 - 5	1	Basic heater with standard equipment 12 V 20 1593 05 00 00
1 - 4	1	12 V 20 1590 05 00 00 (Optional control elements)

Standard equipment comprises:

1	1	Basic heater (not available alone)
2	1	Control unit
3	1	Fuel metering pump with built-in fuel filter
4	3	T-piece 6 x 6, 8 x 6, 12 x 6
5	1	Heating timer (analog) with fasteners

To be ordered in addition:

11-62	1	Universal installation kit 20 1575 80 00 00
-------	---	--

D 1 L

1 - 4	1	Basic heater with standard equipment 12 V 25 1384 05 00 00 24 V 25 1385 05 00 00 12 V 25 1531 05 00 00 24 V 25 1532 05 00 00
-------	---	--

Standard equipment comprises:

1	1	Basic heater (not available alone)
2	1	Control unit
3	1	Fuel metering pump with built-in fuel filter
4	3	T-piece 6 x 6, 8 x 6, 12 x 6

To be ordered in addition: items 5 - 8 optional

5	1	Heating timer (analog) with fasteners	
6	1	Heating timer (digital) with fasteners	
7	1	Universal switch	
8	1	Room thermostat	
9	1	Bulb for universal switch 12 V 207 00 005 24 V 207 00 006	
10	1	Set of connectors	25 1380 89 05 00
11 - 62	1	Universal install. kit	20 1575 80 00 00

Optional control elements

5.



Heating timer with fasteners

Cat. No.

12 V	25 1482 89 09 00
24 V	25 1482 89 10 00

6.



Heating timer with fasteners

Cat. No.

12 V	25 1482 89 19 00
24 V	25 1483 89 02 00

7.



Universal switch

Cat. No.

25 1380 89 04 00

8.

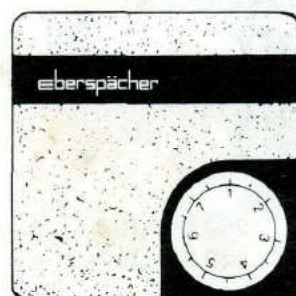

Room thermostat

Cat. No.

black	25 1557 80 01 00
brown	25 1557 80 07 00

Official regulations

For vehicles registered in West Germany (subject to the road traffic regulations StVZO), the heaters are approved by the Federal Motor Vehicle Office and receive an official test symbol (indicated on the name plate).

Please note:

The year of first operation is a requirement of German admission not representing a model number. If the heater is installed in special-purpose vehicles (e. g. vehicles transporting dangerous cargoes), the regulations applicable to such vehicles must be observed.

Installation Instructions

The suggestions put forward in these installation instructions are only examples. Possibilities other than those illustrated (e. g. with regard to the choice of installation location, means of running air) are also permissible, provided they meet the requirements of the West German road traffic regulations (StVZO), and if necessary after consultation with the manufacturer.

Typical installations/installation location

In excavator:

D 1 L
in the cab

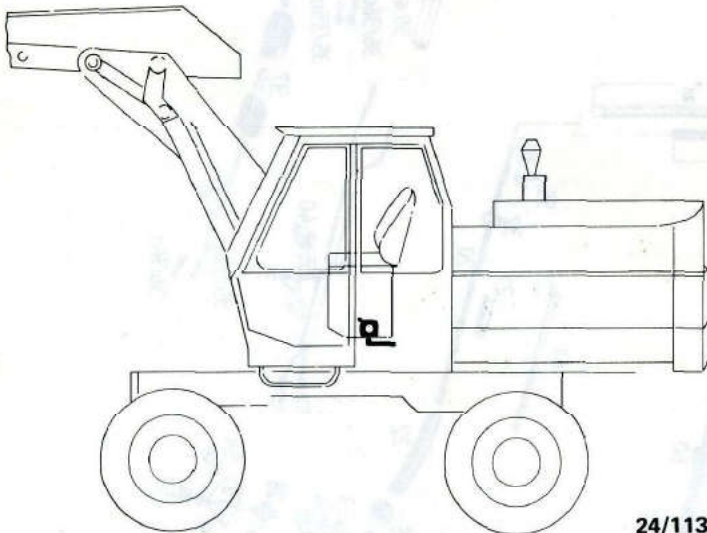

24/113

In truck:

D 1 L
1. on the rear wall of the cab
2. under the seat of the driver

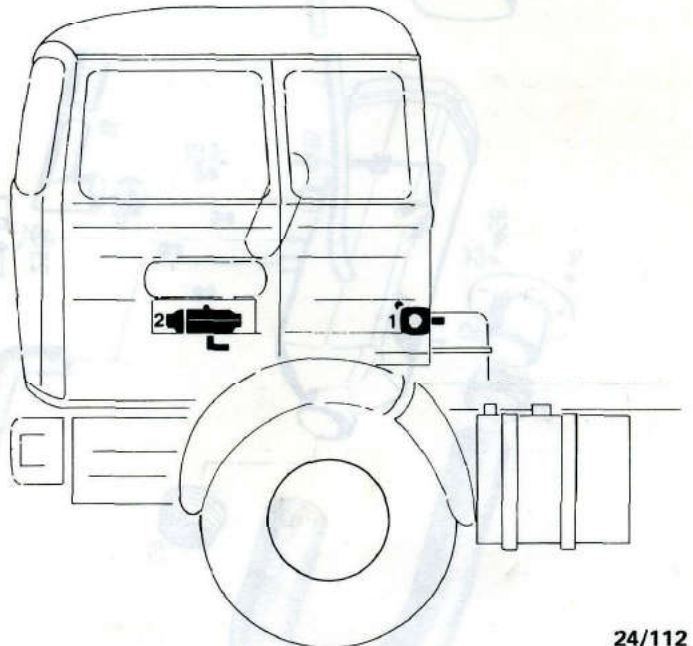

24/112

B 1 L/D 1 L
in vehicle interior

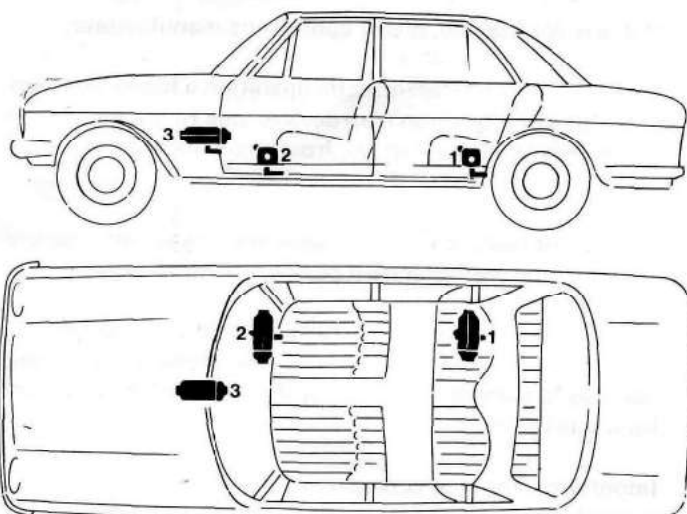

1. Heater under rear seat, inside or outside
2. Heater in front of passenger seat
3. Heater on center console

24/111a

Installing the heater

The B 3 L and D 3 L heaters are suitable and approved for installation in vehicle areas used by passengers.

In the case of installation in passenger areas, the exhaust, combustion air and fuel lines in these areas must not have any detachable connections, and must be splash-water-tight at the penetrations to the outside.

For this reason, the heater must be mounted by its base on an outside panel of the vehicle or on its floor, using the seal seated on the base.

The factory plate must be clearly visible even when installed. If necessary a second factory plate (duplicate) may be affixed, with the same information as the original, to a place on the heater clearly visible after installation, or to a cover placed in front of the heater. A second plate is not necessary if the original is visible after removal of a cover without the aid of tools.

Principal dimensions

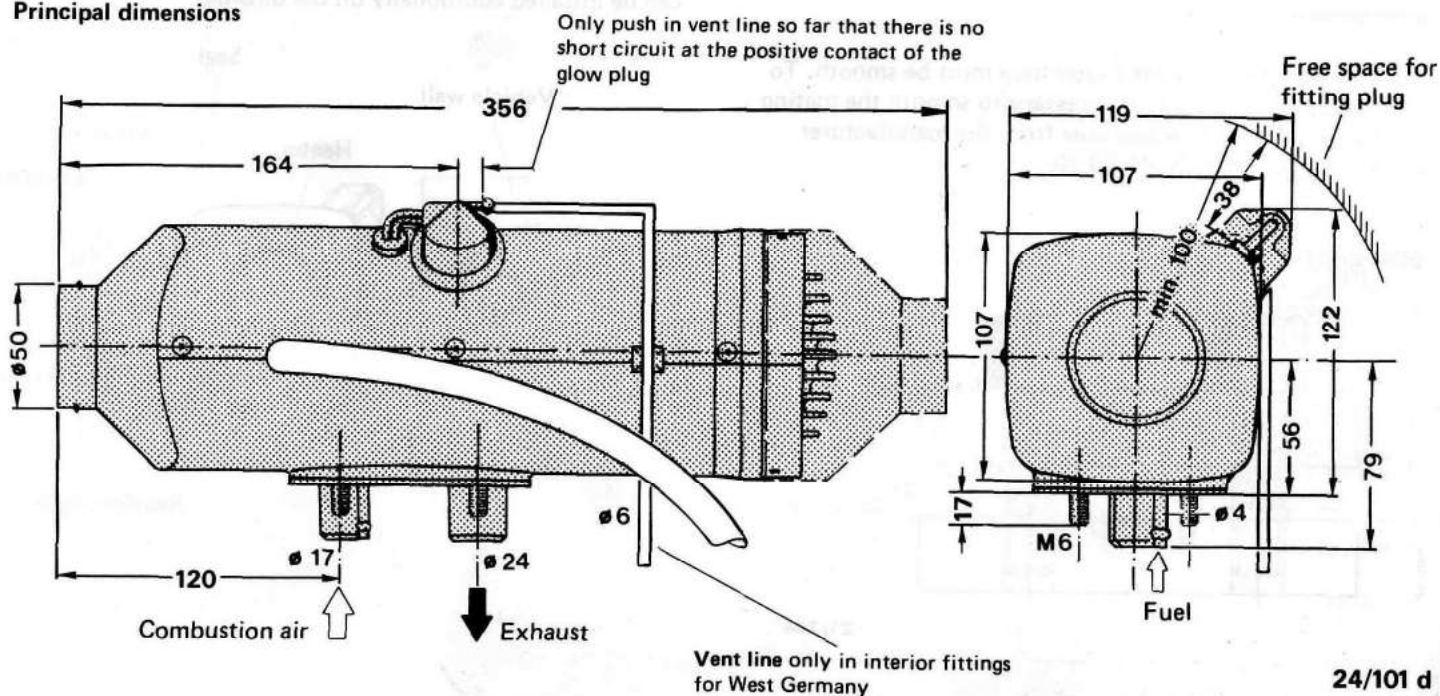

24/101 d

Permissible installation positions

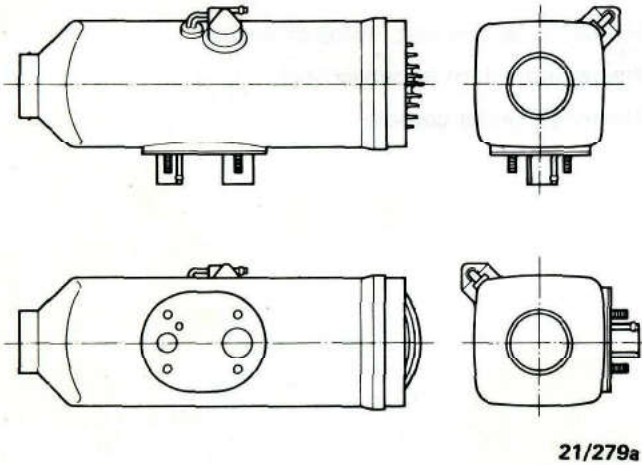

21/279a

In general the heater should be installed in standard position, as shown.

If this is not feasible, please consult the manufacturer.

During starting an thermostatic operation a heater installed in the standard position may deviate, due to the inclination of the vehicle during motion, from this standard position up to $\pm 15^\circ$ in both axes.

Continuous heating operation after starting is even possible at a deviation from standard position of up to $\pm 30^\circ$.

With deviations exceeding $\pm 30^\circ$ a reliable continuous heating operation is no longer possible. However, this does not lead to damage of the heater if the deviation occurs only for a short interval.

Important: The plug connection piece must always face upwards.

Fastening to the vehicle wall/floor

Make penetrations in accordance with the templet pattern.

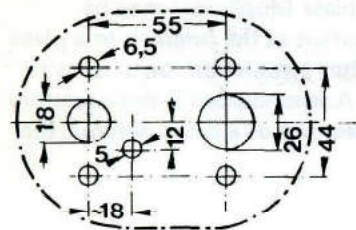

24/101c

Templet pattern

The holes for the 8 mm-dia. vent lines and for the 10.5 mm-dia. metering pump/control unit cable are not included in the templet pattern, and must be drilled to suit the installation arrangement.

The mating surface for the heater base must be smooth. To drill the penetrations and if necessary to smooth the mating surface, a special tool is available from the manufacturer under Cat. No. 99 1201 46 53 29.

Special tool

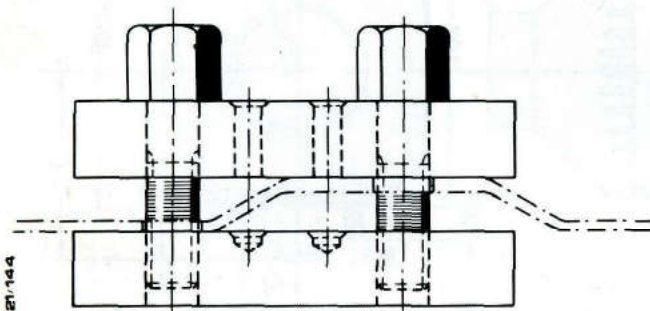

21/144

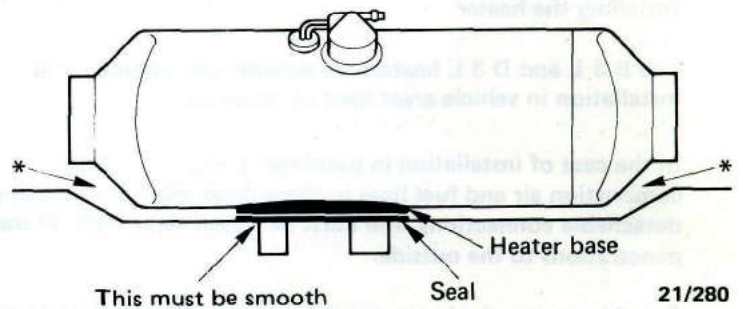

21/280

*This must be kept free. Check for free running of fan wheel.

If the mating surface sheet is too thin (criterion: less than 1.5 mm), a reinforcing plate – Cat. No. 20 1577 89 00 03 – can be installed additionally on the outside.

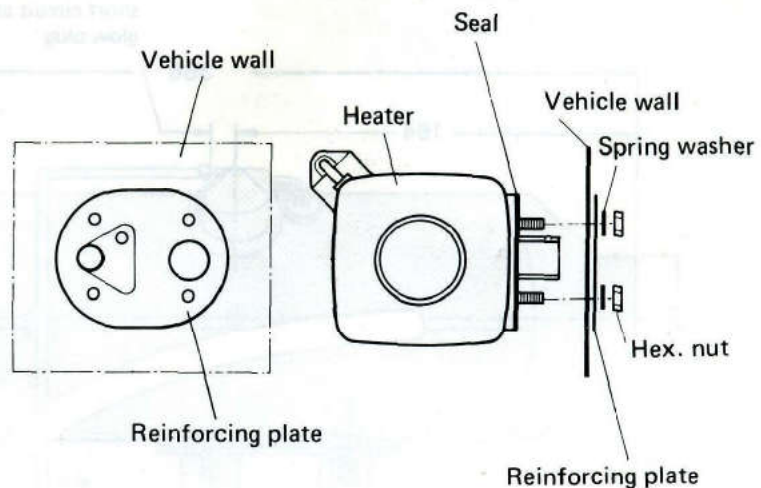

21/281

Running the heating air

Standard components for running heating air.

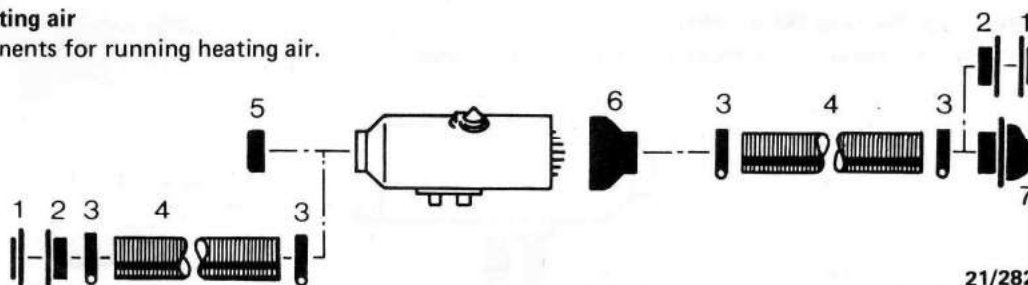

21/282

Item	Designation	Component rating	Cat. No
1	Protective grid	0.4	20 1465 89 05 00
2	Connection piece, 50 mm dia.	0.4	20 1575 80 08 01
3	Hose clip, 50 - 70 mm dia.	—	10 2064 05 00 70
4	Flex. pipe, 50 mm dia. lin. m.	1.0 per m	10 2114 29 00 00
5	Protective grid, 50 mm dia.	0.1	20 1575 89 20 00
6	Hood	0	20 1465 89 00 01
7	Air outlet, rotatable, 50 mm dia.	1.25	20 1575 80 08 00
—	90° bend of flex pipe, 50 mm dia.	0.4	

Do not connect too many components. The sum of the component ratings may not exceed the heater rating. See Additional Equipment Catalog for further parts.

Example of determination of rating:

CAUTION: Do not use a fastening clamp here. The heater casing must not be distorted.

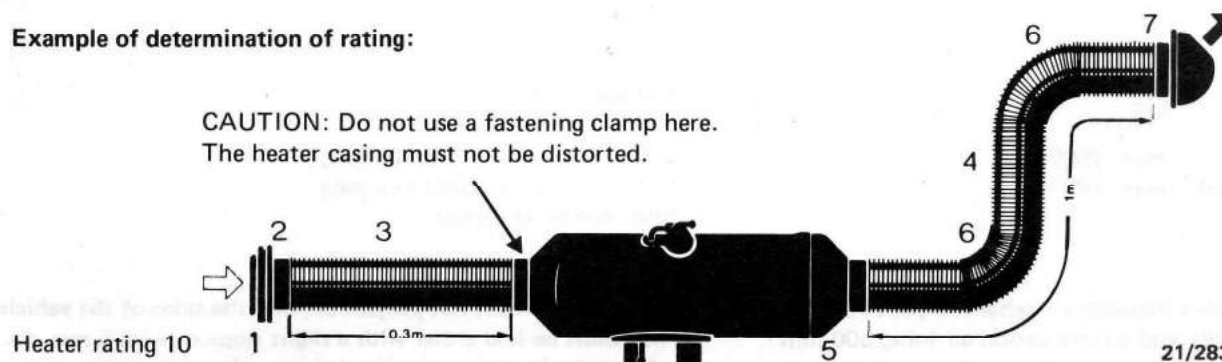

21/283

Item	Designation	Component rating	Cat. No
1	Protective grid	0.4	20 1465 89 05 00
2	Connection piece, 50 mm dia.	0.4	20 1575 80 08 01
3	0.3 flexible pipe, 50 mm dia.	0.3	20 2114 29 00 00
4	1.0 m flexible pipe, 50 mm dia.	1.0	20 2114 29 00 00
5	Reduction hood, 50 mm dia., straight	0.0	20 1465 89 00 01
6	2 x 90° bends of flexible pipe (0.4 rating for each)	0.8	
7	Exhauster, rotatable	1.25	20 1575 80 08 00
Sum of component ratings		4.15	

The sum of the component ratings does not exceed the heater rating of 10, installation is therefore permissible.

When checking an installation, the average outlet temperature should not at the outlet point significantly exceed 110°C with an intake temperature of 20°C. This will ensure that the safety thermal cutout switch will not respond under normal operating conditions.

Heating air intake openings shall be arranged in such a manner that exhaust from the vehicle's engine and from the heater cannot be expected to be sucked in under normal operating conditions, and the heating air cannot be contaminated.

When operating as a recirculating heater, locate the inlet for the heating air in such a way that the outflowing hot air cannot be sucked directly in again.

Running the combustion air/Running the exhaust

Permissible diameters, lengths, bends of combustion air and exhaust lines.

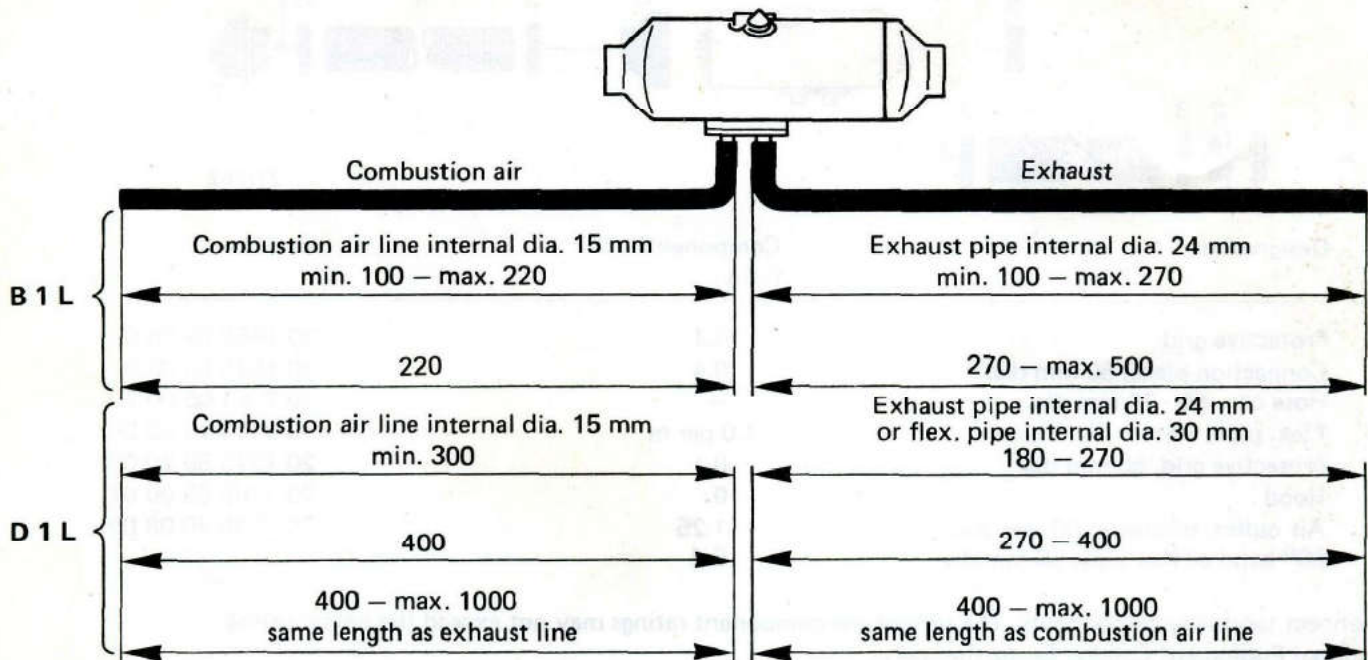

Measurements in millimeters

21/284

Permissible bend

Exhaust line: max. 180°
Combustion air line: max. 180°

The scope of delivery includes an exhaust pipe, 270 mm long, with 90° bend, and a combustion air tube, 500 mm long, with 90° bend.

These can be shortened as required. Longer pipes are available as given in the Additional Equipment Catalog.

Additional noise suppression is possible by installing an exhaust silencer (see chapter "Exhaust Parts" in the Additional Equipment Catalog). The permissible length of the exhaust line is reduced here by the length of the exhaust silencer.

The combustion air must be sucked in from the outside, not from the passenger compartment or trunk.

Do not install the intake opening facing the slipstream, but run it in such a manner that dirt and snow cannot enter and that any water which does enter can flow out.

Exhaust lines

B 1 L max. 500 mm long
D 1 L max. 1000 mm long
must not be exceeded.

Exhaust lines must not project beyond the sides of the vehicle. They must be laid either with a slight slope or with 5 mm dia. holes at the lowest points for draining off condensate.

Arrange the exhaust outlet and the combustion air opening such that the exhaust cannot be sucked back in directly.

The exhaust outlet must be on the outside. Exhaust lines must be laid in such a way that neither the penetration of exhaust into the vehicle interior nor the intake of exhaust through the vehicle or heater blowers need be expected¹⁾, and that the operation of essential vehicle parts is not affected (ensure adequate clearance). Place the outlet opening of the exhaust line in such a way that it cannot be clogged by dirt and snow and that any water which does enter can run off.

¹⁾ This requirement can be considered met if the outlet opening of the exhaust line is located at the usual places in motor vehicles, e.g. in engine compartment, in wheel case, on the vehicle underside, or on the rear of the cab.

Fuel supply

1. Fuel intake fuel line to engine (usually in passenger cars):

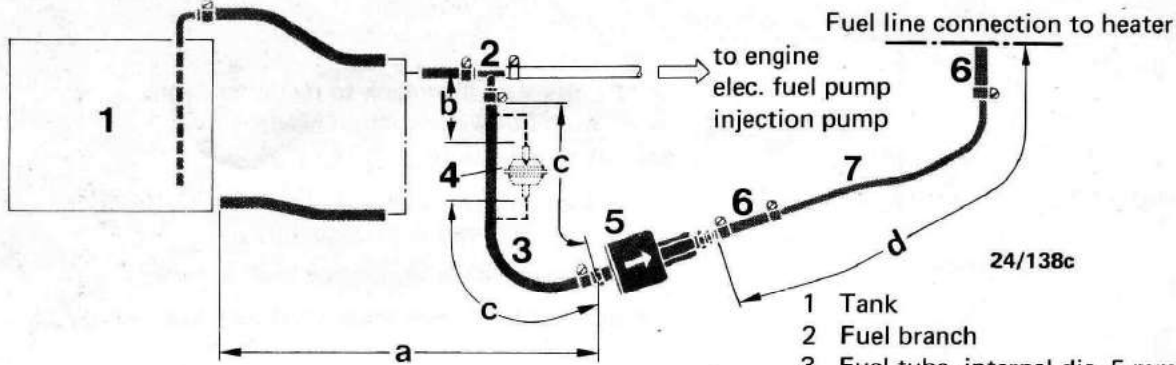

- Dimension a = max. 750 mm for gasoline
max. 2000 mm for diesel oil
- Dimension b = 50 mm
- Dimension c = max. 300 mm
- Dimension d = max. 4 m for gasoline
max. 6 m for diesel oil

- 1 Tank
2 Fuel branch
3 Fuel tube, internal dia. 5 mm
4 Fuel pre-filter (vertical, up to 30° downward if fuel line is tapped)
Cat. No. 25 1226 89 00 37, only necessary if fuel is contaminated
5 Fuel metering pump (15° to vertical, inclined upward)
6 Fuel tube, internal dia. 3.5 mm
7 Fuel pipe, plastic, internal dia. 1.5 mm
8 Tank connection, internal dia. 2 mm
9 Tube or plastic pipe (max. internal dia. 5 mm)
10 Fuel pipe, plastic, internal dia. 2 mm

At all joints, fuel pipe (7) and connection pieces must touch.

2. Fuel intake separately from fuel tank or separate tank (usually in trucks, construction machinery, agricultural machinery)

- A = intake from above
B = lateral intake at tank
C = lateral intake or beneath it; metering pump below lowest fuel level

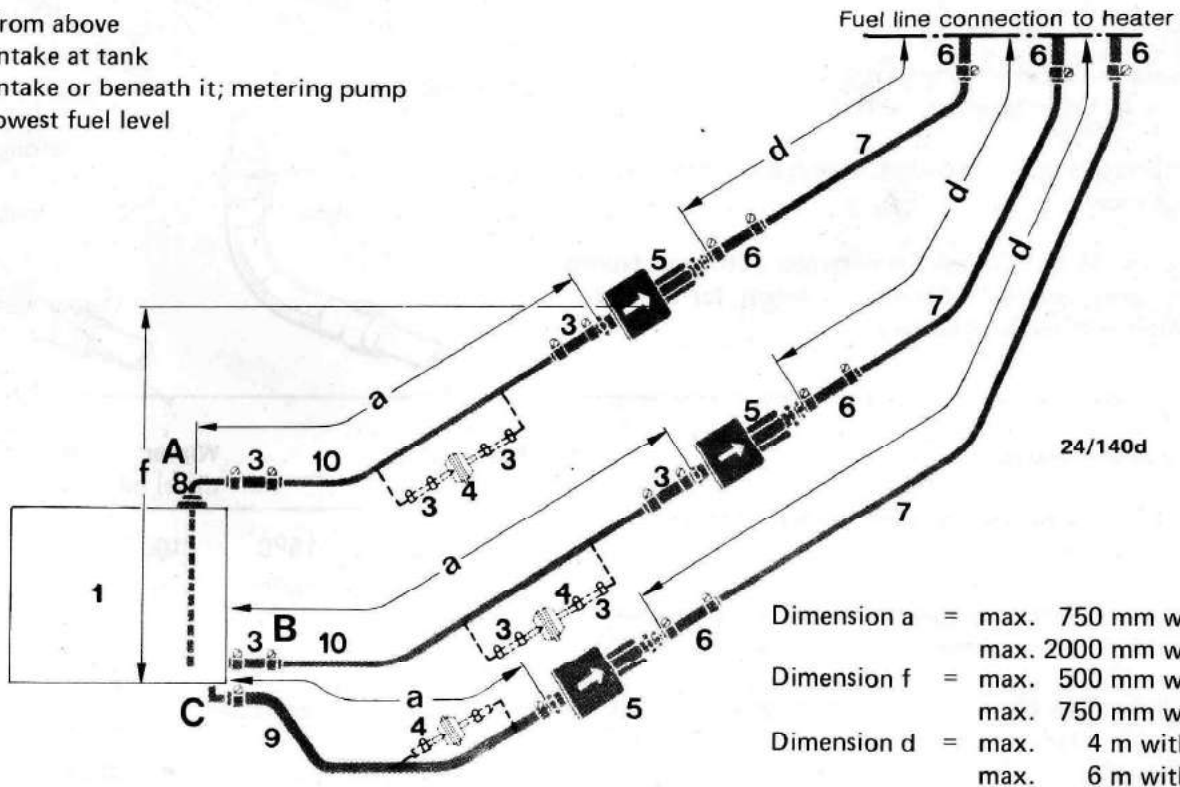

- Dimension a = max. 750 mm with gasoline
max. 2000 mm with diesel oil
- Dimension f = max. 500 mm with gasoline
max. 750 mm with diesel oil
- Dimension d = max. 4 m with gasoline
max. 6 m with diesel oil

With connection types A and B, the intake line – A includes tank connection (8) – including all connection points must have an internal dia. of 2 mm; for this reason, fuel pipe (10) and connections must touch each other at every joint.

3. Permissible suction and pressure heads for installation per 1. and 2.;
permissible positioning of metering pump

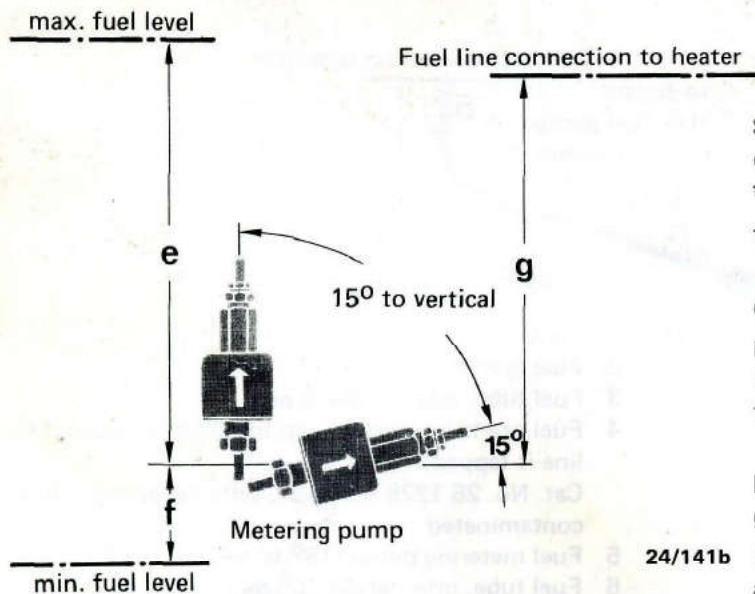

Supply pressure from tank to metering pump:

- e = max. 3000 mm suction head:
tank at zero pressure
- f = max. 500 mm with gasoline
max. 750 mm with diesel oil

Check whether tank ventilation works properly

intake from tank when underpressure occurs during operation
(valve 0.03 bar in tank cap)

- f = max. 150 mm with gasoline
max. 400 mm with diesel oil

Pressure head metering pump to heater:

- g = max. 2000 mm

Fuel line metering pump to heater should not have a slope if at all possible.

4. Important

Protect fuel lines, filter and metering pump from overheating; do not install near silencers and exhaust pipes. Temperatures above 30° C lead to gas bubbles and problems with gasoline.

When installing the fuel line, fuel filter and fuel metering pump near the rear axle, be sure to take the spring deflection of the rear axle into consideration.

Cut fuel tubes and pipes to length only with a sharp knife. Cuts may not be indented and must be burr-free.

For connection of the fuel branches, always use rubber tubing, never plastic pipe.

Sections 45 and 46 of the West German road traffic regulations StVZO also apply, with due alteration of details, for the fuel lines and additional tanks of heaters.

Fuel pipes connected by means of a fuel tube.

Fuel pipe sections must abut.

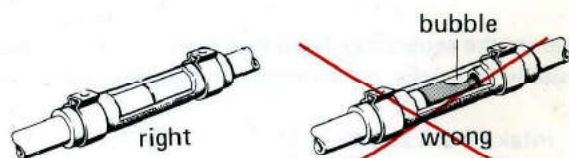

Do not let fuel tube sag.

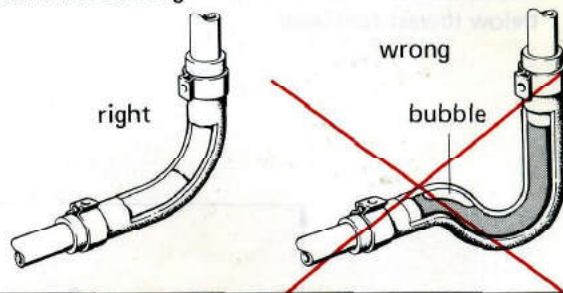

Fuel at low temperatures:

The heater can take without problem the same fuel you use in your tank.

The refineries automatically adapt their fuels to normal winter temperatures (Winter Diesel).

Therefore difficulties can only arise at extremely low temperature (as in the engine – see the vehicle's instruction manual).

If the heater is operated from a separate tank, the following rules must be observed: at temperatures above 0° C any type of diesel fuel can be used.

If no special cold-weather diesel fuel is available at low temperatures, mix kerosine or gasoline according to the adjacent table.

Temperature	Winter diesel oil	Additive
From 0°C to -15°C	100 %	—
From -15°C to -25°C	50 %	50 % kerosine or gasoline
From -25°C to -40°C	—	100 % kerosine*

*or special winter diesel oils

The fuel line and the fuel pump must be filled with new fuel by operation for 15 minutes.

Fuel for special cases

In special cases, the heaters can also be operated on extra light fuel oil (above 0°C) or kerosine. If in doubt consult the manufacturer.

Electrics:

Arrange electric cables, switches and control units in the vehicle in such a way that their correct functioning cannot be impaired under normal operating conditions.

Fit the control unit so that it is protected from splash water (from both its own vehicle and preceding ones). Outside installation is thus not permissible. The unit is best arranged in the vehicle interior, with the plugs pointing downward.

Control unit

Permissible installation angles

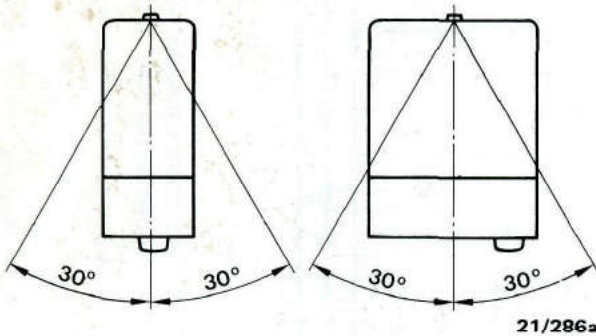

The pilot light (built into the switch or timer) should be within the field of vision of the driver, or at least be visible to him without great effort.

Install the room thermostat where it is sheltered from draughts and sunlight. Do not fit it to non-insulated outer walls.

The following cable cross-sections must be observed between battery and heater, in order that the maximum permissible voltage losses in the cables (0.5 at 12 V rated voltage and 1 V at 24 V) are not exceeded.

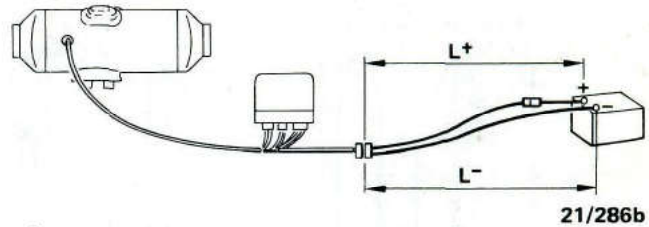

$L^+ + L^- < 5 \text{ m} \rightarrow$ cross-section 4 mm^2

$L^+ + L^- 5 \text{ to } 8 \text{ m} \rightarrow$ cross-section 6 mm^2

If the positive cable is to be connected to the fuse box (e.g. terminal 30), the vehicle's cable too from the battery to the fuse box must be included in the calculation of the total line length, and if necessary redimensioned in accordance with the above.

Smear plug and earth connections with contact protection grease outside the vehicle interior.

See page 12 – 16 for parts list to wiring diagrams

- | | |
|--------------------------------|---------------------------|
| 1 Blower motor | |
| 2 Glow plug | |
| 3 Temperatur switch | |
| 4 Safety thermal cutout switch | |
| 7 Glow plug drop resistor | |
| 8 Temperature fuse | |
| 10 Control unit | |
| 11 Motor fuse | |
| 12 Relay for glow plug | |
| 13 Fuel metering pump | |
| 14 Main fuse 16 Amp. | |
| 17 Timer | |
| 18 Thermostat | } Optional addition parts |
| 21 Universal switch | |
| 24 Circulation pump | |

- rt = red
- br = brown
- ws = white
- sw = black
- gn = green
- ge = yellow
- vi = violet

- = Heating
- = Ventilation
- 0 = Off

WIRING DIAGRAM

B 1 L - 12 V - 20 1593 05 00 00
 12 V - 20 1590 05 00 00

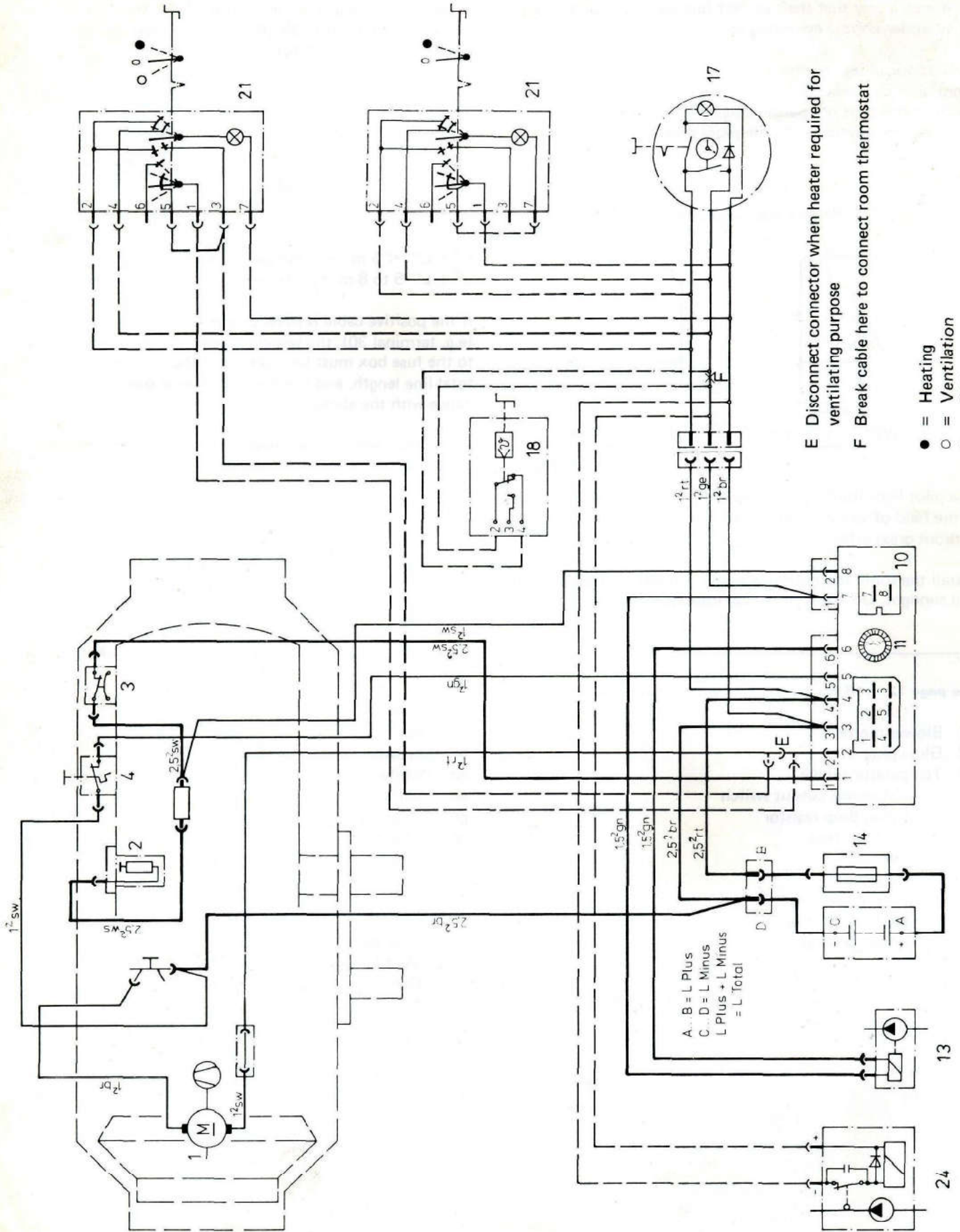

E Disconnect connector when heater required for ventilating purpose

F Break cable here to connect room thermostat

- = Heating
- = Ventilation
- 0 = Off

D 1 L - 12 V - 25 1384 05 00 00

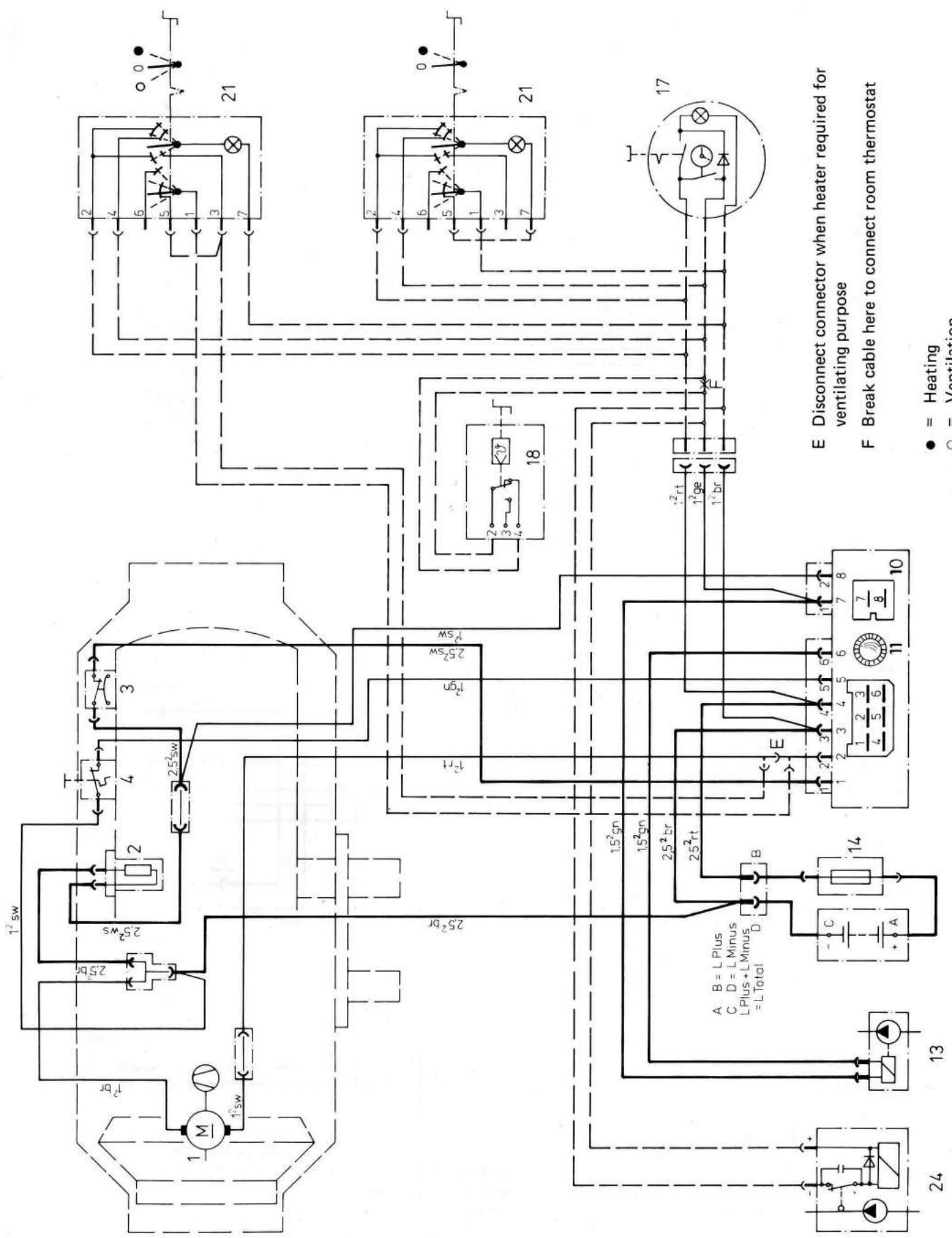

E Disconnect connector when heater required for ventilating purpose

F Break cable here to connect room thermostat

- = Heating
- = Ventilation
- 0 = Off

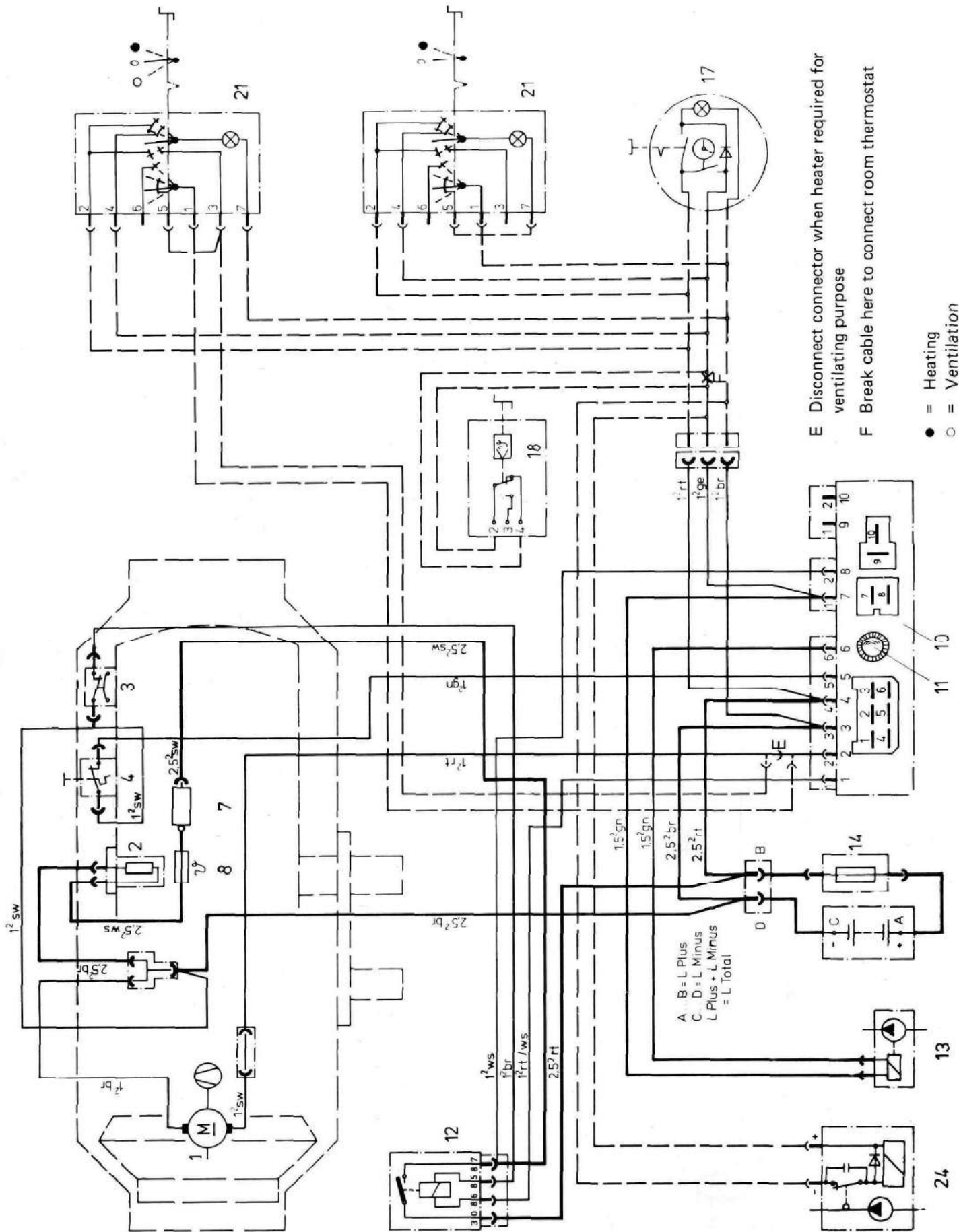

E Disconnect connector when heater required for ventilating purpose

F Break cable here to connect room thermostat

- = Heating
- = Ventilation
- 0 = Off

Description of Operation

D 1 L: shown complete
 B 1 L: differences shown in inset

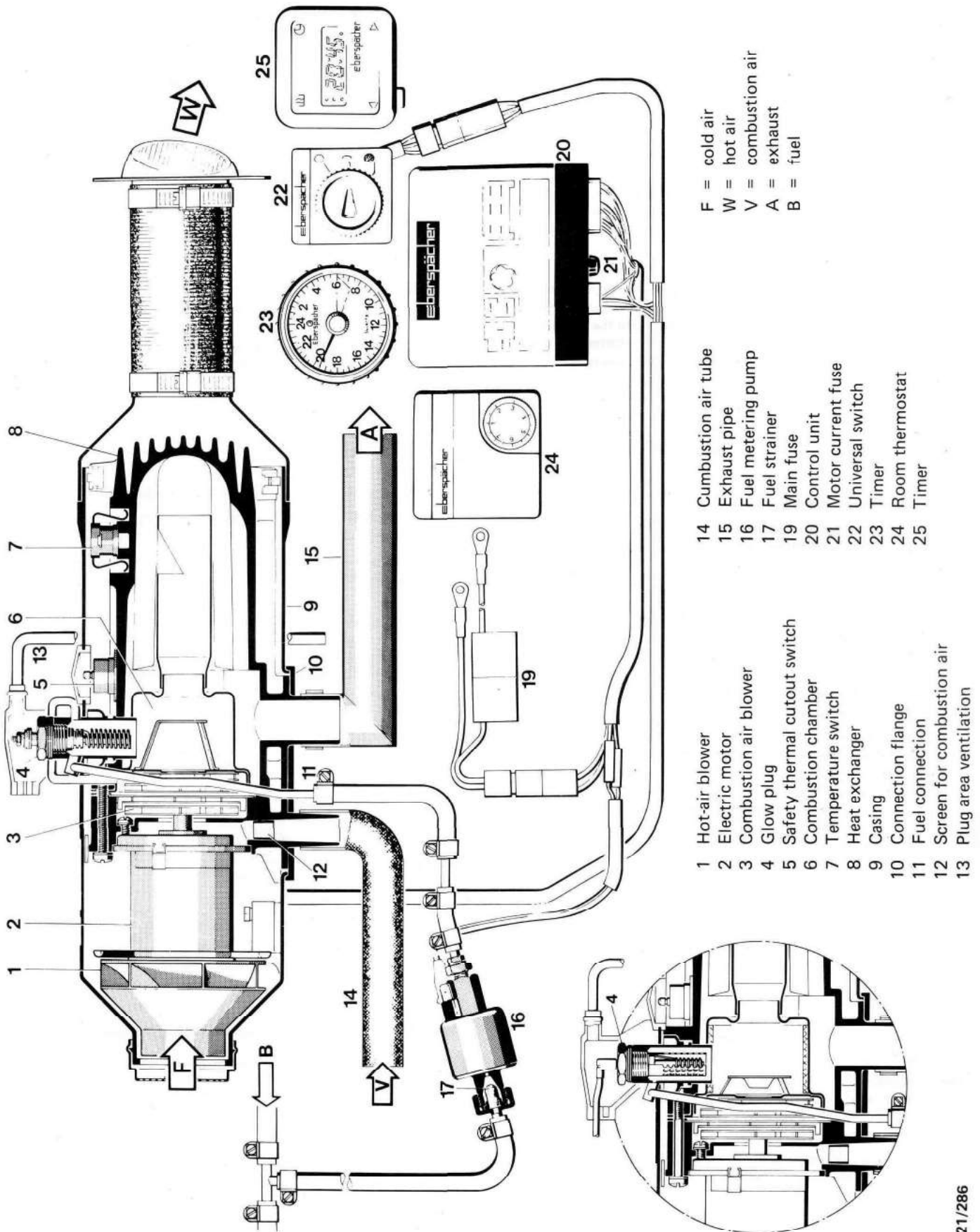

Description of operation

Heaters D 1 L and B 1 L are of identical design wherever practicable. The differing fuel types however make design differences unavoidable.

Control elements

A choice is possible between:

1. Universal switch (22)
Switch position: Heating or Ventilation
If other switches generally used in motor vehicles are employed, they must be able to take at least 10 A.
2. Timer (23/25)
Using the timer, the heater can be switched on at once or the switch-on time can be preselected up to 22 hours in advance.
3. Room thermostat (24)
A room thermostat can also be used in conjunction with the universal switch or timer. It should however be remembered that the load on the battery is greater and that wear on plugs will be heavier.

Mode of operation

The pilot lamp comes on when the heater is switched on, the hot-air blower begins after no more than 5 seconds to convey hot air, and the combustion air blower to convey combustion air. Simultaneously, the fuel metering pump conveys precise quantities of fuel into the combustion chamber¹⁾. Fuel and combustion air here form an inflammable mixture which is ignited at the glow plug. The combustion gases now pass through the heat exchanger and activate the temperature switch, which switches off the glow plug. The hot air is heated at the heat exchanger and passes through the exhauster into the area to be heated. When the heater is switched off, the pilot lamp goes off, but the blower motor runs until the heater has cooled down. Then it is automatically switched off by the temperature switch.

Controls and safety equipment

The flame is monitored by the temperature switch. This switch acts on the safety switch in the control unit, which switches off the heater in the event of a malfunction.

Sequence after switching on:

- a) The temperature switch switches off the glow plug when a stable flame has been obtained. In addition, after the heater has been switched off, it automatically stops the blower when the heater has cooled down.
- b) If the heater fails to ignite, it switches off automatically not more than 3 minutes after being switched on.
If a defect in the blower motor has caused the heater to switch off, the motor current fuse installed in the control unit may have been tripped. Check it and replace if necessary. The heater can be switched back on by briefly switching it off and back again. If the motor current fuse blows repeatedly, have the blower fault remedied. Do not switch the heater back on more than twice. If it still does not start, remedy the malfunction in accordance with the Troubleshooting and Repair Manual.
- c) Should the flame extinguish spontaneously during operation, the heater will automatically switch off after no more than 4 minutes. It can be switched back on in accordance with b).
- d) The safety thermal cutout switch stops the fuel metering pump if the maximum permissible temperature for the heating air is exceeded (e. g. in the event of the heating air ducts becoming blocked). The heater then switches off automatically. After removal of the cause of overheating and pressing of the knob on the safety thermal cutout switch, the heater can be put back into operation by switching it off and on again.
- e) The glow plug monitor in the control unit – D 1 L heaters 25 1531 and 25 1532 only – prevents fuel being pumped when the glow plug is defective and when the temperature fuse on the glow plug series resistor has blown (25 1532 only).
- f) Heaters No. 25 1385 switch off automatically after about 3 minutes when the temperature fuse on the glow plug series resistor has blown.

- g) Undervoltage safety device
An undervoltage safety device built into the control unit switches off the heaters when the voltage at the control unit drops below approx. 10.5 V or 21 V, as the case may be.
- h) Overvoltage safety device
In the case of B 1 L and D 1 L heaters, models 25 1384 and 25 1385, an overvoltage safety device built into the control unit switches off the heaters when the voltage at the control unit exceeds 15 V and 30 V respectively.

IMPORTANT! Heaters with undervoltage safety device may only be operated with the appropriate control units (with replaceable motor current fuse).

You can remedy the following malfunctions yourself:

1. The blower cannot be heard after the heater is switched on:
 - a) Check the 16 A fuse in the cable harness of the heater.
 - b) Check the motor current fuse in the control unit (heaters Nos. 25 1531 05 and 25 1532 05 only).

Important! Only the following Eberspächer spare part fuse inserts (special monitored design) may be used:

for 12 V
fuse insert TT 4, blue marking, no 460 26 016
Cat. No., for two: 25 1531 05 02 00

for 24 V
fuse insert TT 2, yellow marking, no 460 26 000
Cat. No., for two: 25 1532 05 02 00

The use of other fuse inserts may lead to damage in the control unit in the event of a fault.

- c) Check the glow plug and replace it if necessary.
2. After the heater is switched on, the blower only runs for about 3 minutes, the heater does not ignite and automatically switches off.
Briefly switch the heater off and back on again (not more than twice). If the heater still does not ignite, have the trouble seen to in a workshop.
 3. The heater goes off during operation:
If the fault is due to overheating, switch the heater off, eliminate the cause of the overheating (e. g. blocked hot-air pipe), press the safety thermal cutout switch (1) and switch the heater back on.

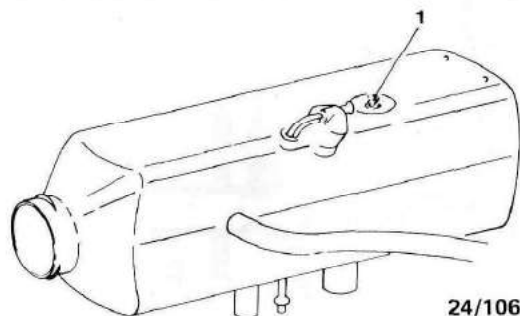

Remember that heaters 25 1531 and 25 1532 only start to work 5 seconds after being switched on.

The pilot lamp in the universal switch comes on immediately after the heater is switched on.

Please note:

1. The heater must never be switched on while the tank is being filled.
2. The heater must not be operated in garages.
3. The vehicle battery must be disconnected during electrical welding work on the vehicle in order to protect the control unit.

¹⁾ With heaters Nos. 25 1482, 25 1483 and 25 1573, the blower runs approx. 5 seconds after switch-on, the fuel metering pump about 25 seconds following switch-on.